



BFN6 System Board



About this Document

This guide provides insights into the diverse features of this product and the necessary steps for setup. It's designed for individuals who are:

In charge of setting up, managing, and addressing issues with this system, like IT experts.

Presumed to possess proficiency in computer equipment servicing, including seasoned system integrators and technical staff.

Acknowledgment

All product names and/or trademarks are properties of their respective owners.

Copyright and Trademarks

This document is copyrighted © 2024 by Boingfire Systems. All rights are reserved. Boingfire Systems reserves the right to make enhancements to the products detailed in this manual at any time without prior notice.

No portion of this manual may be duplicated, replicated, translated, or conveyed in any manner or through any medium without the explicit written consent of Boingfire Systems.

Details provided in this manual aim to be precise and trustworthy. However, Boingfire Systems assumes no liability for its application, nor for any potential violations of third-party rights that might arise from its use.

Technical Support

Besides reaching out to your distributor or sales agent, there are alternative avenues to seek support from Boingfire:

Email Us

support@boingfire.com

Compliances and Certification

CE

This product has passed the CE test for environmental specifications. Test conditions for passing included the equipment being operated within an industrial enclosure. To protect the product from being damaged by ESD (Electrostatic Discharge) and EMI leakage, we strongly recommend the use of CE-compliant industrial enclosure products.

FCC Class A

This equipment has been tested and found to comply with the limits for a Class A digital device, pursuant to Part 15 of the FCC Rules. These limits are designed to provide reasonable protection against harmful interference when the equipment is operated in a commercial environment. This equipment generates, uses, and can radiate radio frequency energy and, if not installed and used in accordance with the

instruction manual, may cause harmful interference to radio communications. The operation of this equipment in a residential area is likely to cause harmful interference in which case the user will be required to correct the interference at his own expense.

EMC Notice

This equipment has been tested and found to comply with the limits for a Class A digital device, pursuant to Part 15 of the FCC Rules. These limits are designed to provide reasonable protection against harmful interference when the equipment is operated in a commercial environment. This equipment generates, uses, and can radiate radio frequency energy and, if not installed and used in accordance with the instruction manual, may cause harmful interference to radio communications. The operation of this equipment in a residential area is likely to cause harmful interference in which case users will be required to correct the interference at their own expense.

Safety Guidelines

Adhere to these precautions for optimal safety:

- Ensure the chassis vicinity remains clean and devoid of dust during and post-installation.
- Avoid wearing garments or accessories that might entangle in the chassis. Secure ties or scarves and tuck in your sleeves.
- Employ protective eyewear if operating under conditions potentially harmful to your eyesight.
- Refrain from actions that pose risks to individuals or compromise the equipment's safety.
- Before installing, removing a chassis, or being near power sources, disconnect all electrical connections by switching off and unplugging the power cord.
- Avoid operating in potentially dangerous situations unaccompanied.
- Never presume a circuit is power-free; always conduct a thorough check.

Lithium Battery Caution

- Risk of Explosion if Battery is replaced by an incorrect type. Dispose of used batteries according to the instructions.
- Installation only by a trained electrician or only by an electrically trained person who knows all English Installation and Device Specifications which are to be applied.
- Do not carry the handle of power supplies when moving to another place.
- The machine can only be used in a fixed location such as labs or computer facilities.

Operating Safety

- Electrical equipment generates heat. Ambient air temperature may not be adequate to cool equipment to acceptable operating temperatures without adequate circulation. Be sure that the room in which you choose to operate your system has adequate air circulation.
- Ensure that the chassis cover is secure. The chassis design allows cooling air to circulate effectively. An open chassis permits air leaks, which may interrupt and redirect the flow of cooling air from internal components.

- Electrostatic discharge (ESD) can damage equipment and impair electrical circuitry. ESD damage occurs when electronic components are improperly handled and can result in complete or intermittent failures. Be sure to follow ESD-prevention procedures when removing and replacing components to avoid these problems.
- Wear an ESD-preventive wrist strap, ensuring that it makes good skin contact. If no wrist strap is FW-8894 User Manual available, ground yourself by touching the metal part of the chassis.
- Periodically check the resistance value of the antistatic strap, which should be between 1 and 10 megohms (Mohms).

Installation Precautions

Environmental:

- Do not install and/or operate this unit in any place that flammable objects are stored or used in.
- If installed in a closed or multi-unit rack assembly, the operating ambient temperature of the rack environment may be greater than room ambient. Therefore, consideration should be given to installing the equipment in an environment compatible with the maximum ambient temperature (T_{ma}) specified by the manufacturer.
- Installation of the equipment (especially in a rack) should consider the ventilation of the system's intake (for taking chilled air) and exhaust (for emitting hot air) openings so that the amount of air flow required for safe operation of the equipment is not compromised.
- To avoid a hazardous load condition, be sure the mechanical loading is even when mounting.
- Consideration should be given to the connection of the equipment to the supply circuit and the effect that overloading of the circuits might have on over-current protection and supply wiring. Appropriate consideration of equipment nameplate ratings should be used when addressing this concern.
- Reliable earthing should be maintained. Particular attention should be given to supply connections other than direct connections to the branch circuit (e.g. use of power strips).
- Boingfire Systems shall not be held liable for any losses resulting from insufficient strength for supporting the unit or use of inappropriate installation components.

Installation & Operation:

- The installation of this product must be performed by trained specialists; otherwise, a non-specialist might create the risk of the system's falling to the ground or other damages.
- Boingfire Systems shall not be held liable for any losses resulting from insufficient strength for supporting the system or use of inappropriate installation components.

CHAPTER 1: Introduction

PRODUCT OVERVIEW

These are some highlights to give you better understanding about BFN6 System Board.

- ✓ Tailored for fanless network appliances like routers, firewalls, VPNs, IPBX, and IoT gateways.
- ✓ Fully compatible with open-source operating systems including CentOS, OpenBSD, OPNsense, and FreeBSD, making it a prime choice for open-source enthusiasts.
- ✓ Designed for ultra-low power consumption, cutting energy usage by 20% compared to rival products.
- ✓ Enhanced thermal design ensures unparalleled stability, especially within confined spaces.
- ✓ Powered by an Intel Atom E3845 CPU with 4 cores, running at a frequency of 1.91GHz and equipped with a 2MB L2 cache.
- ✓ Uses DDR3L technology at 1333MHz, supporting up to 8GB of data with a single 204-pin SODIMM socket.
- ✓ Features one Micro-HDMI port, capable of supporting a resolution up to 2560 x 1600 at 60Hz.
- ✓ Offers up to 3 Ethernet interfaces with an Intel i210 controller and RJ45 connectors.
- ✓ One SFP Port for Fiber connectivity.
- ✓ Equipped with a system reset output and a flexible timer ranging from 1-255 seconds to 1-255 minutes.
- ✓ Comes with full-sized mSATA, an eMMC slot exclusive for Boingfire Modules, and a SATAII interface with 3.0 Gb/s transfer rates.
- ✓ Houses 3 serial ports, a Micro-HDMI output, dual reset, and power buttons, four USB ports (including one USB 3.0), and a 20-bit GPIO.
- ✓ Three Mini PCIe slots designed for 4G/LTE and Wi-Fi functionalities.
- ✓ Requires a 12V power input with a variance of +/- 10%, and on a minimal system setup, it consumes a mere 0.5A@12V (5.28W).
- ✓ Measures at 160 x 152 mm, weighing 0.45 kg with its heatsink. Can operate between 0-60°C and sustain non-operating temperatures of -40°C to 85°C

System Specifications

- **Design Features**
 - Ultra-low power consumption: 20% lower than competitors.
 - Superior thermal design ensuring stability, especially in closed housing.
- **Processor**
 - CPU: Intel Atom E3845

- Cores: 4
- Frequency: 1.91GHz
- L2 Cache: 2MB
- BIOS: AMI 64 Mbit
- Encryption Support: AES-NI
- **Memory**
 - Technology: DDR3L 1333MHz
 - Capacity: Up to 8GB
 - Socket: 1 x 204-pin SODIMM
- **Display**
 - Micro-HDMI Port: 1
 - Max Resolution: 2560 x 1600 at 60Hz
- **Ethernet**
 - Interfaces: Up to 3
 - Controller: Intel i210 Gigabit
 - Connector: RJ45
- **SFP Port**
 - Connector: SFP
 - Giga SFP Fiber Module/SFP RJ45 Module
- **Watchdog Timer**
 - Output: System Reset
 - Adjustable Timer: 1-255s, 1-255min, with a disabled option
- **Storage**
 - mSATA: 1 (full size)
 - eMMC: 1 (Compatible with Boingfire Module only)
 - SATA: 1 (SATAII with transfer rates up to 3.0 Gb/s)
- **Internal I/O**
 - Serial Ports: 3 (1 x RS-232, 2 x TTL with transfer rate up to 1Mbit/s)
 - HDMI: 1
 - Reset Buttons: 2 (back & front)
 - Power Buttons: 2 (for system wake)
 - USB Ports: 3 x USB2.0, 1 x USB3.0
 - GPIO: 20-bit GPIOs
- **Expansion**
 - Mini PCIe1: For 4G/LTE
 - Mini PCIe2: For 4G/LTE, WiFi
- **Power**
 - Input: 12V= \pm 10%
 - Consumption: 0.5A@12V (5.28W) for a minimal system (Without addon Card)
- **Operating Environment**
 - Temperature: 0 ~ 60° C (32 ~ 140° F)
 - Humidity: 40° C @ 95% RH non-condensing
- **Storage Environment**
 - Temperature: -40° C ~ 85° C and 60° C @ 95% RH non-condensing

- **Physical Specifications**
 - Dimensions: 160 x 152 mm (6.3" x 5.99")
 - Weight: 0.45 kg (0.99 lb) with heatsink
 - Total Height: 33mm (including cooler, PCB, and bottom)
- **Module**
 - TPM2.0 (Optional)

TOP VIEW

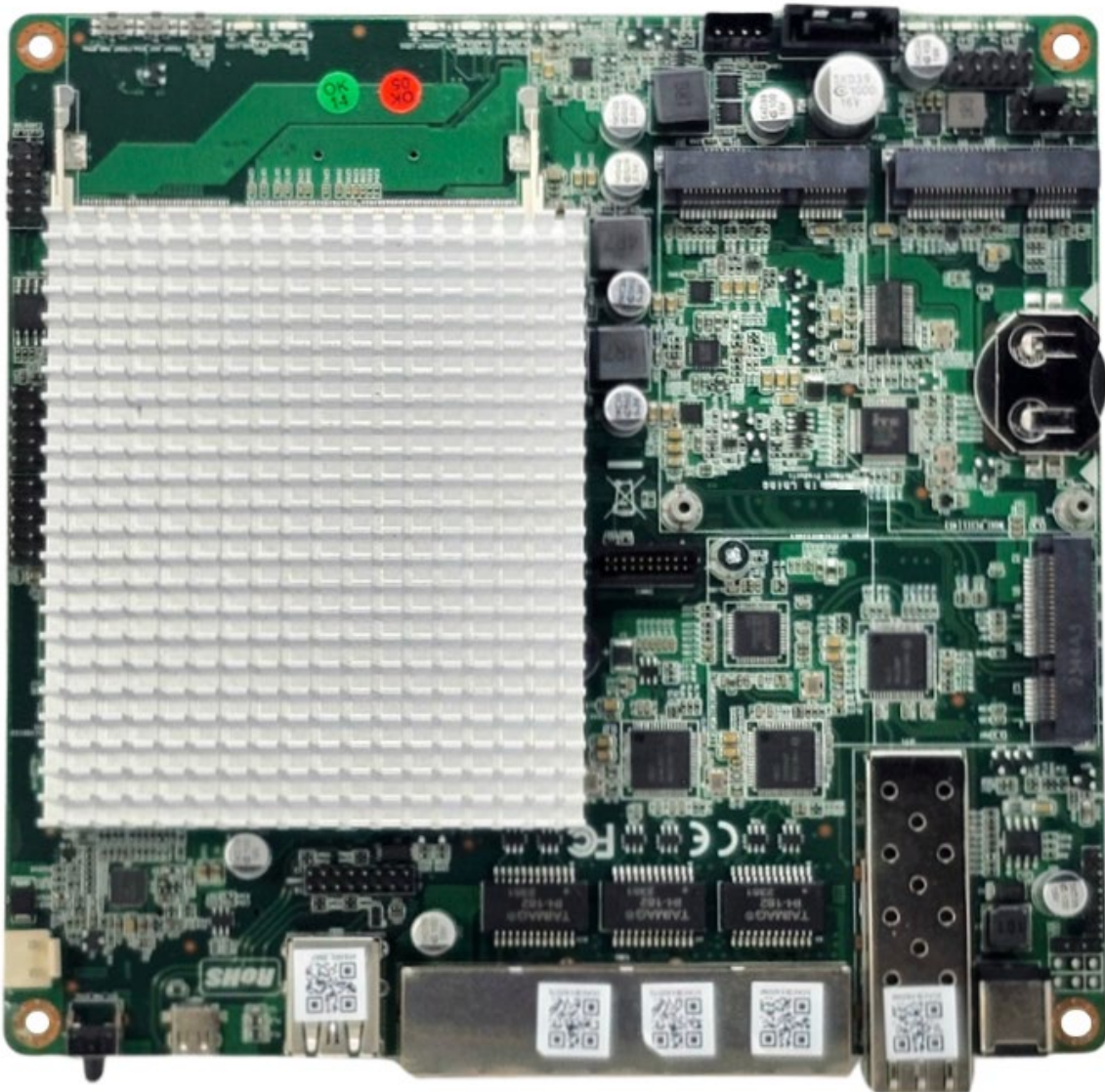

BOTTOM VIEW

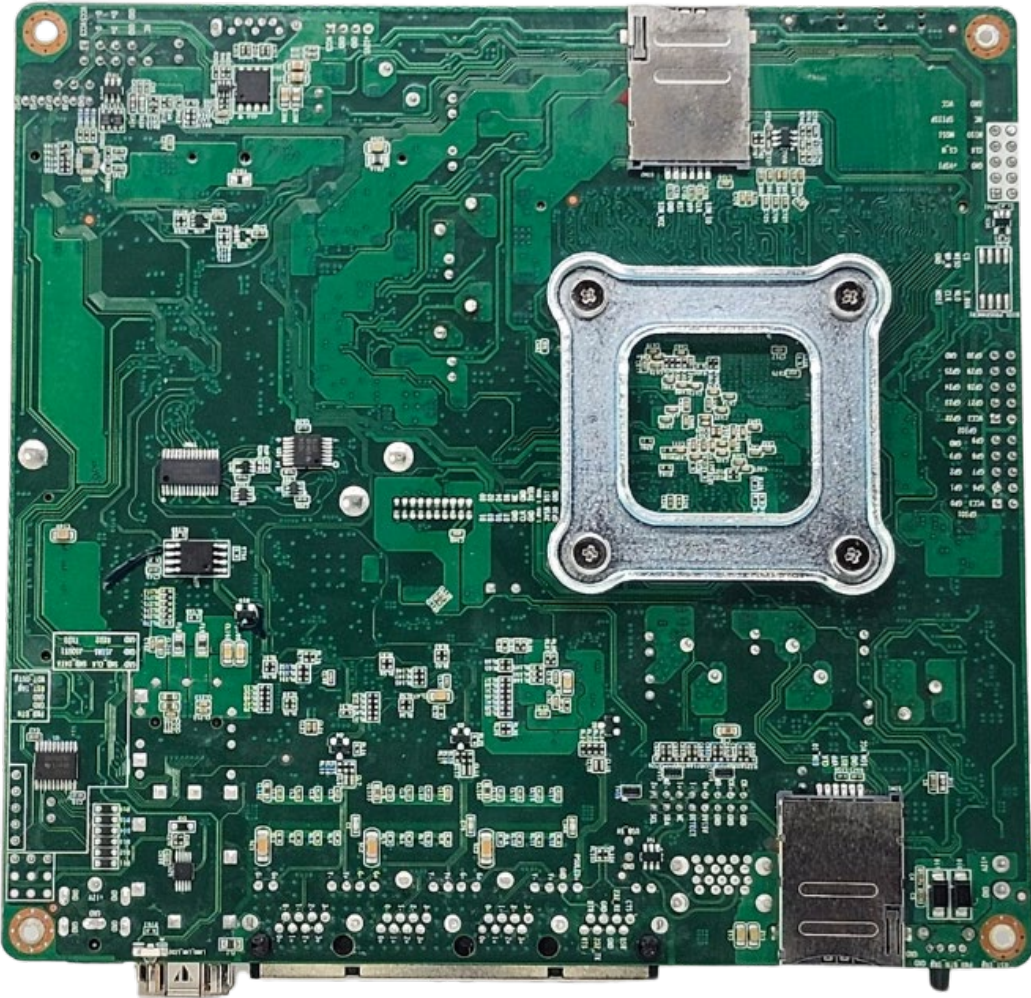

Dimension OF BFN6

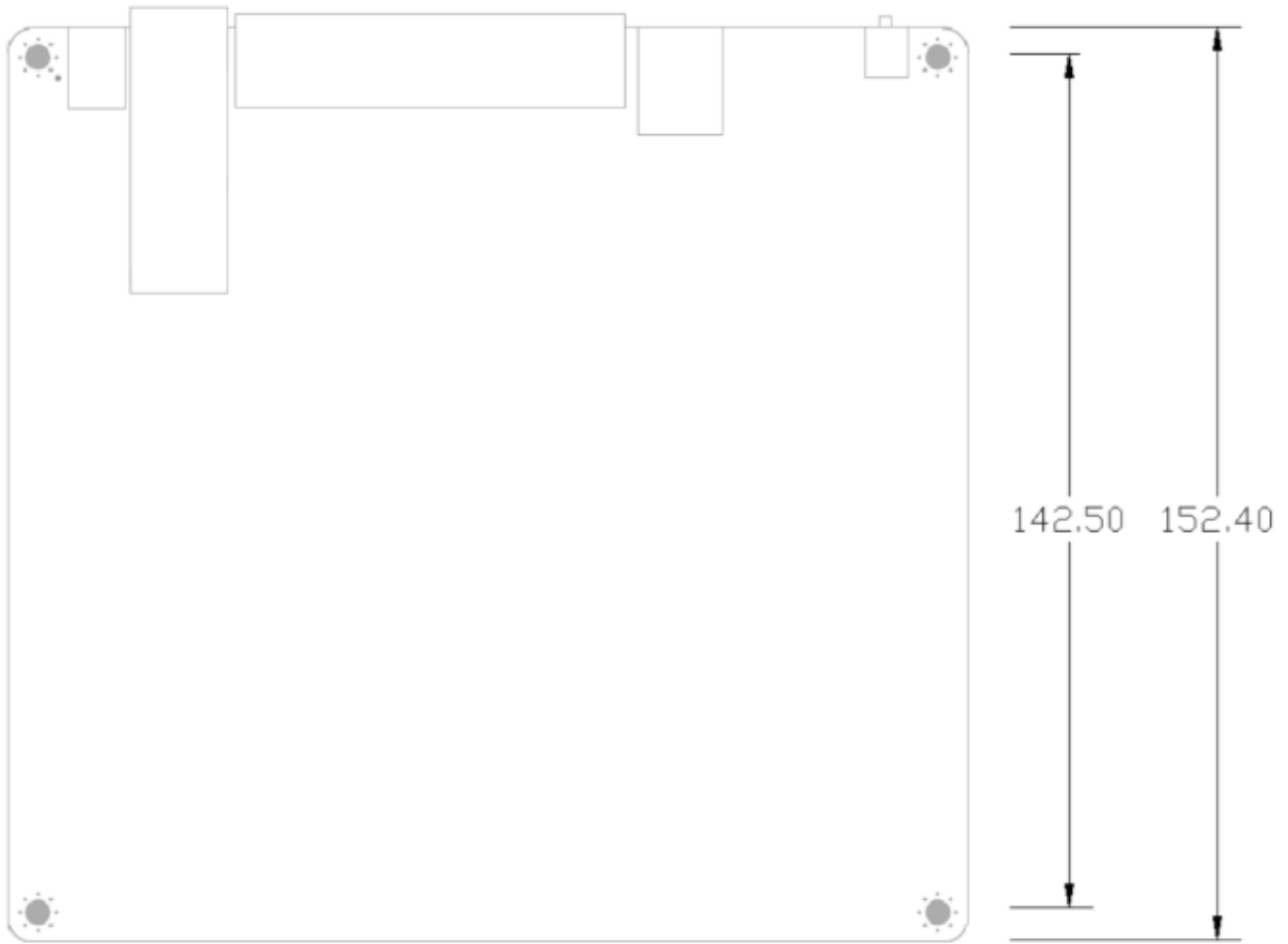

2D and 3D images are available, contact your distributor/reseller for more information.

Some conditions apply.

CHAPTER 2: CONNECTOR LAYOUT

Here all the connectors from the top of BFN6 are mentioned.

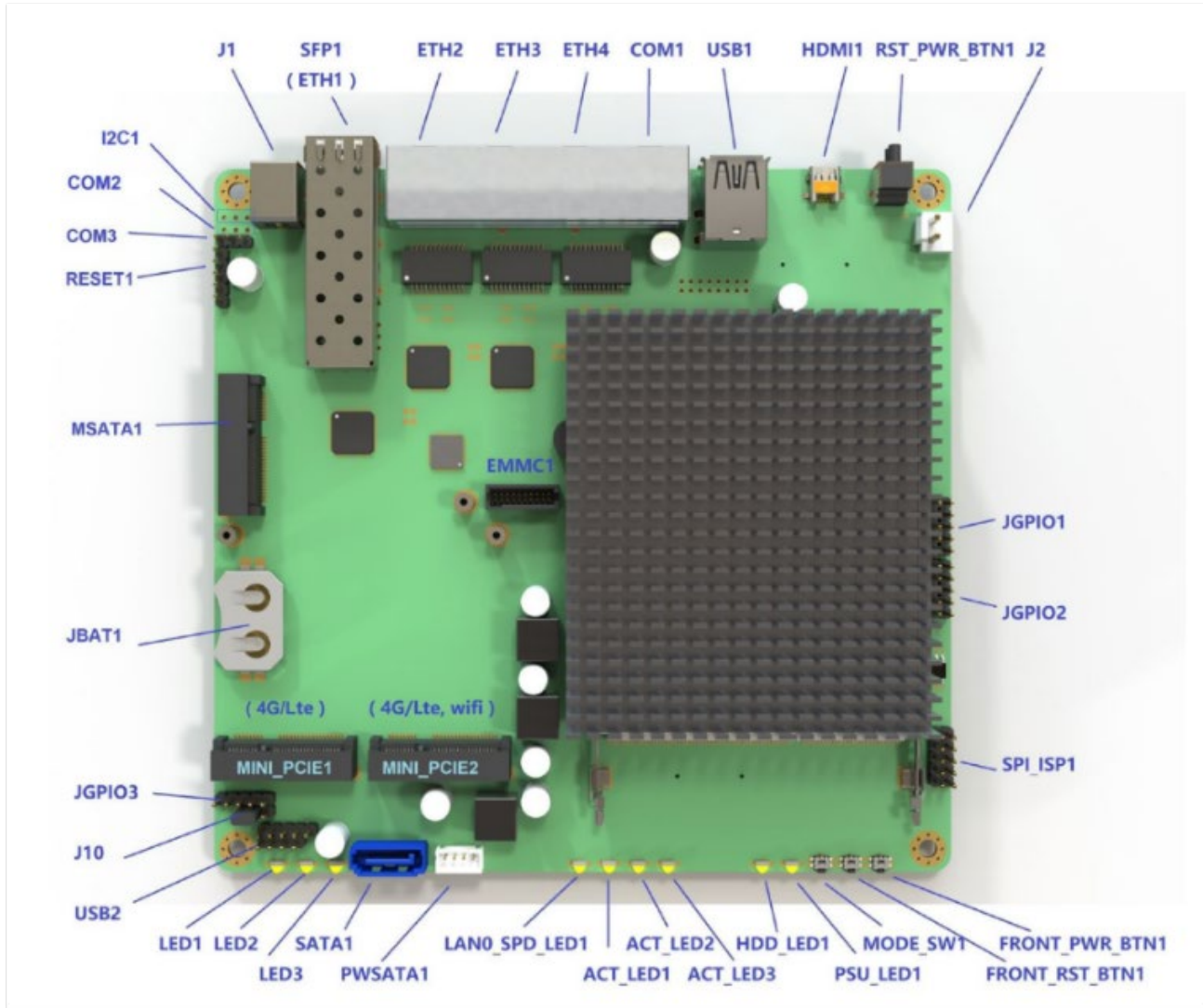

At the bottom of the board connector shown in the image below.

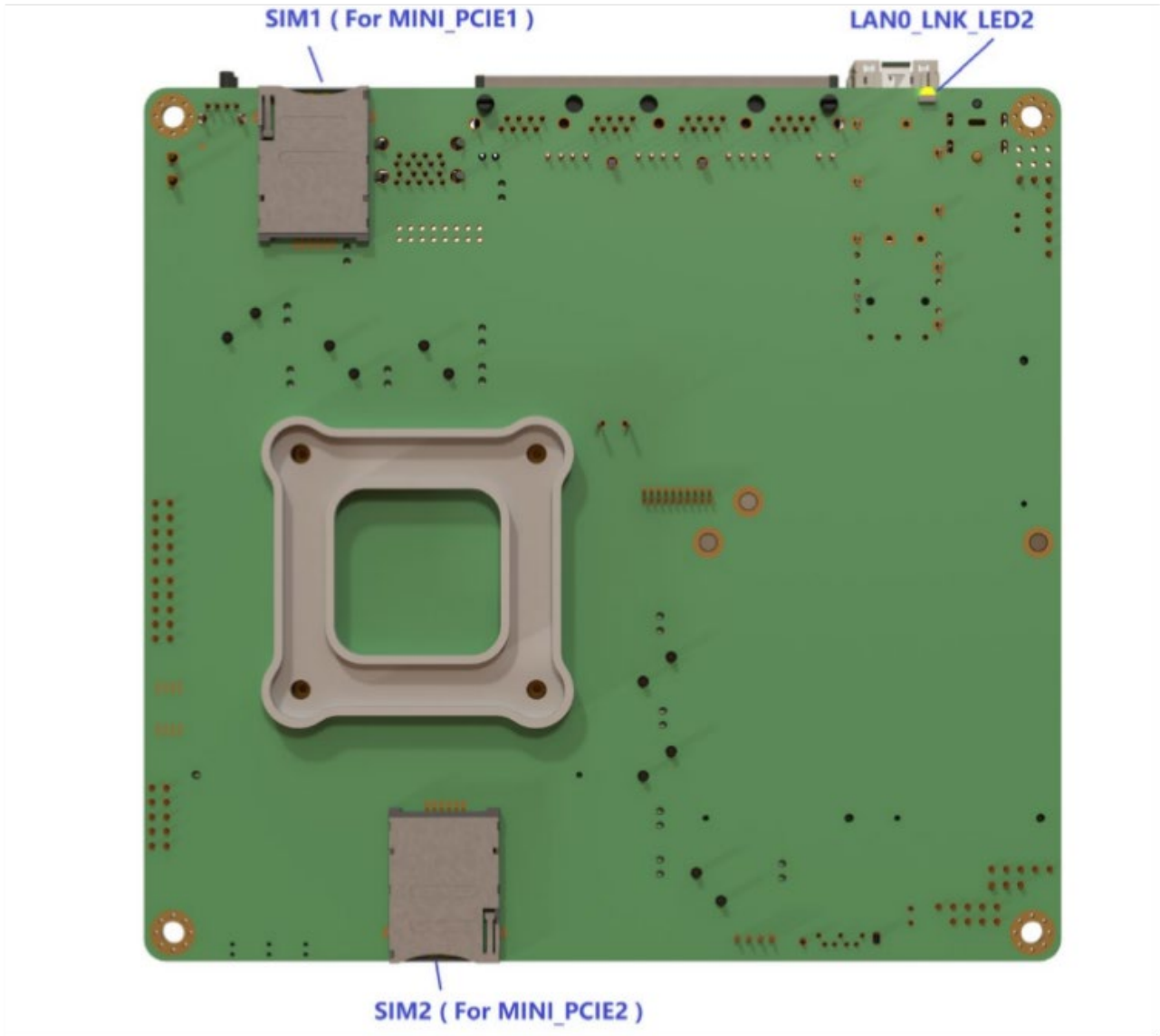

BFN6 I/O Port Layout

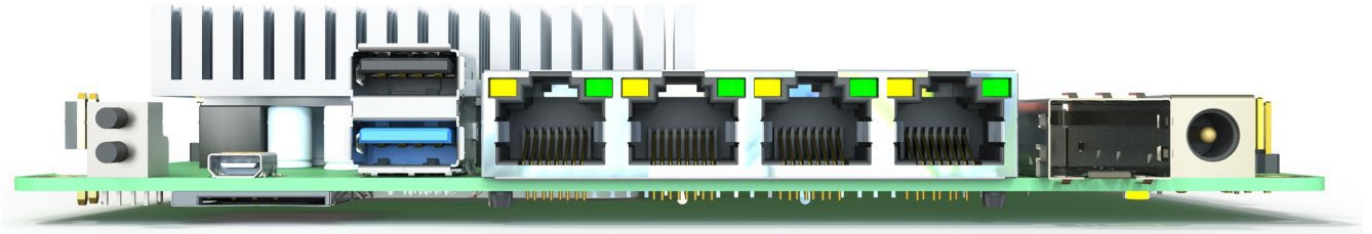

Connectors List

Compact design for small enclosures.

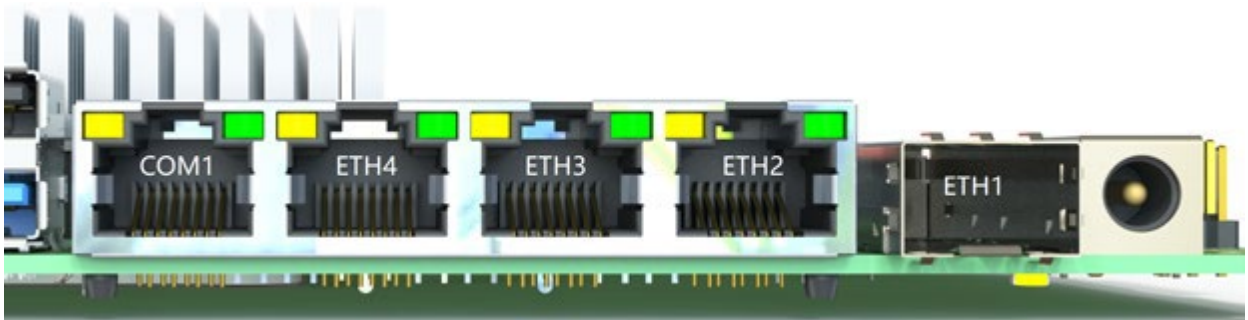

RJ45 Console port Support remote PC accessing.

PIN	NAME	PIN	NAME
1	RTS	2	DTR
3	TXD	4	GND
5	GND	6	RXD
7	DSR	8	CTS

Support typical baud rate from 9600bps ~ 115200bps (115200 default).

Baud rate setting in BIOS

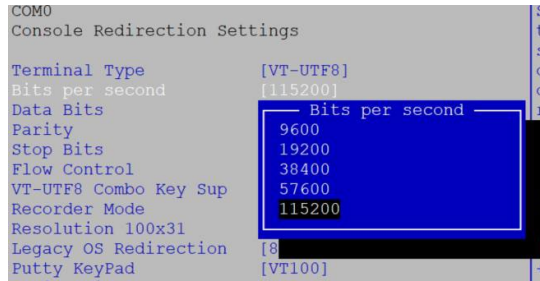

Baud rate setting in FreeBSD

```
root@:/ # vi /boot/loader.conf
console="comconsole"//select serial port as console
comconsole_speed=115200// 115200 is recommended
autoboot_delay="0"// waiting time setting
```

Recommended settings on Putty (Remote MS Windows OS)

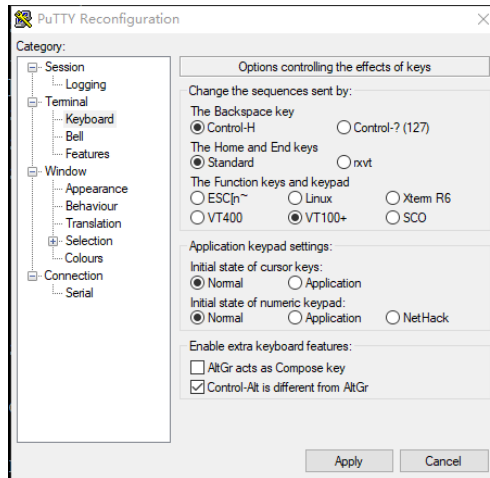

SFP1 (ETH1):

The port support Giga SFP fiber module, or SFP RJ45 module.



(ETH2~ ETH4) Definition:

PIN	NAME	PIN	NAME
1	MDI_0+	2	MDI_0-
3	MDI_1+	4	MDI_2+
5	MDI_2-	6	MDI_1-
7	MDI_3+	8	MDI_3-

In FreeBSD, ETH1 ~ ETH4 correspond to igb0 ~ igb3 Respectively.

```
root@:~ # uname -a
FreeBSD 12.0-RELEASE FreeBSD 12.0-RELEASE r341666 GENERIC amd64
root@:~ # dmesg | grep address
igb0: Ethernet address: 1c:ae:3e:e6:1d:28 ETH1 (SFP Port)
igb1: Ethernet address:1c:ae:3e:e6:1d:29 ETH2
igb2: Ethernet address:1c:ae:3e:e6:1d:2a ETH3
igb3: Ethernet address: 1c:ae:3e:e6:1d:6d ETH4 (Network Port close to COM1)
```

IP Setting

```
root@:/ # vi /etc/rc.conf
clear_tmp_enable="YES"
sendmail_enable="NONE"
hostname=""
#ifconfig_igb0="DHCP" // dhcp
ifconfig_igb0="inet192.168.1.210 netmask 255.255.255.0" //static IP on igb0
ifconfig_igb1="inet 192.168.7.210 netmask 255.255.255.0" //static IP on igb1
ifconfig_igb2="inet192.168.8.210netmask 255.255.255.0" //static IP on igb2
ifconfig_igb3="inet192.168.9.210netmask 255.255.255.0"
sshd_enable="#"YES"
# Set dumpdev to "AUTO" to enable crash dumps, "NO" to disable
dumpdev="AUTO"
sshd_enable=yes //sshd
```

COM2 (BLANK)

It's the copy of RJ45 console port COM1, RS232 level.
The port would be available as soon as pin header soldered.

PIN	NAME
1	TXD
2	RXD
3	GND

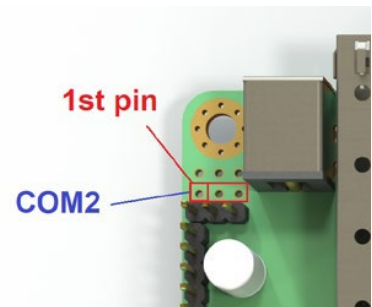

COM3: (TTL level)

The TTL level serial ports are from a USB bus convert chip CH340.

PIN	NAME
1	TXD
2	RXD
3	GND

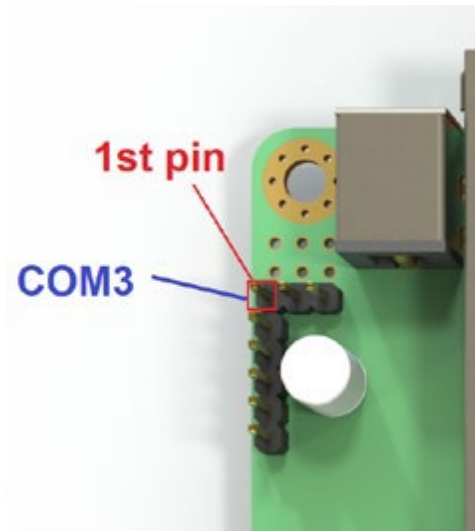

I2C1 (BLANK):

The port would be available as soon as pin header soldered.

I2C1 Definition

PIN	NAME
1	DATA
2	CLK
3	GND

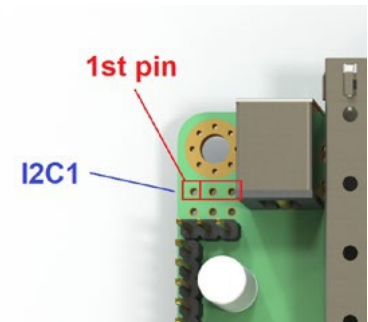

HDMI Connector (HDMI1)

HDMI is micro-HDMI female connector. Use a Micro HDMI male to HDMI female cable for connect monitor to BFN6 Board

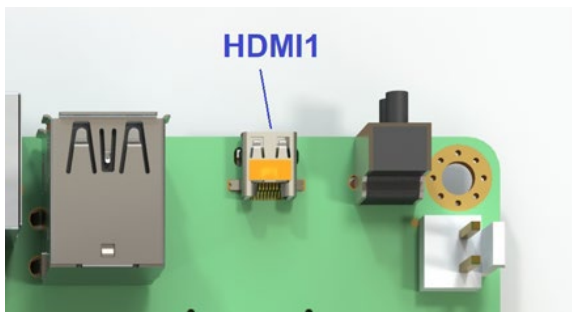

RST_PWR_BNT1

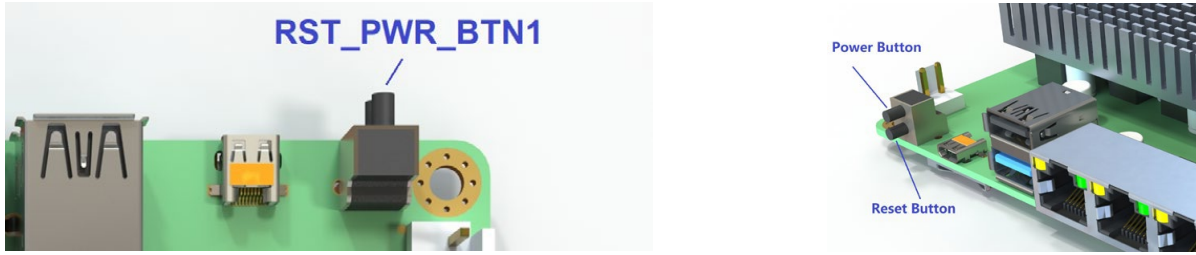

Position	FUNCTION
Upper	Power Button
Lower	Reset Button

FRONT_PWR_BTN1 & FRONT_RST_BTN1 & MODE_SW1

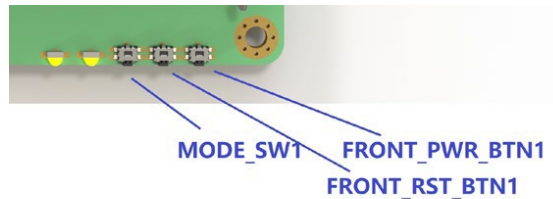

PIN	NAME
MODE_SW1	GPIO pin. GPIO_S0_SC56 of SOC (pin BC12)
FRONT_RST_BTN1	Rest Button
MODE_SW1	Power Button

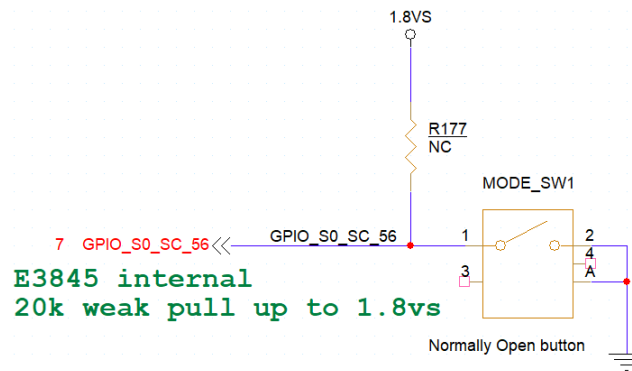

LED1, LED2, LED3

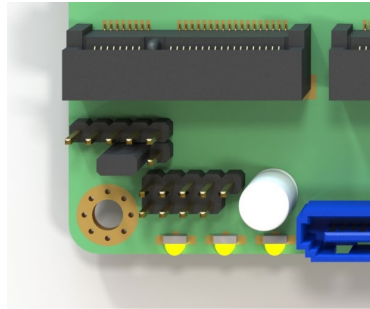

LED1 LED2 LED3

NAME	FUNCTION
LED1	GPIO pin Wired out from GPIO_S0_SC60 of SOC (pin BD16)
LED2	GPIO pin Wired out from GPIO_S0_SC59 of SOC (pin BF14)
LED3	GPIO pin Wired out from GPIO_S0_SC58 of SOC (pin BC14)

E3845

GPIO_S0_SC55	BD12	
GPIO_S0_SC56	BC12 GPIO_S0_SC_56	
GPIO_S0_SC57	BD14	
GPIO_S0_SC58	BC14 SOC_LED3_GP58	>>>SOC_LED3_GP58
GPIO_S0_SC59	BF14 SOC_LED2_GP59	>>>SOC_LED2_GP59
GPIO_S0_SC60	BD16 SOC_LED1_GP60	>>>SOC_LED1_GP60
GPIO_S0_SC61	BC16 GPIO_S0_SC_61	

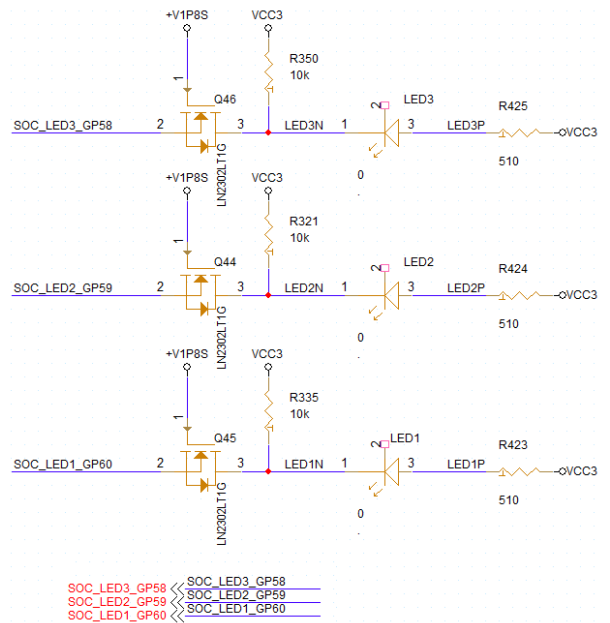

HDD_LED1,PSU_LED1, LAN0_SPD_LED1,ACT_LED1,ACT_LED2,ACT_LED3

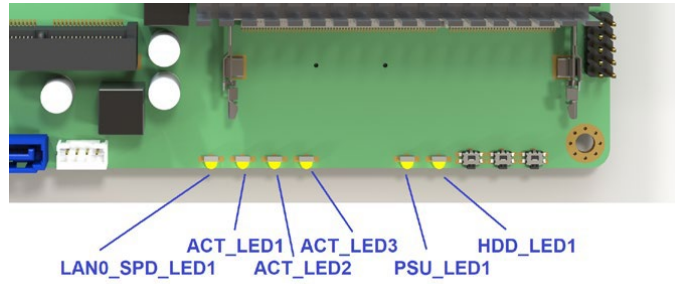

NAME	FUNCTION
HDD_LED1	HDD Activity light, blink when HDD in reading/writing
PSU_LED1	Power Status. Light off in case system is in shutdown (S4)
LAN0_SPD_LED1	Activity LED of SFP1 (ETH1)
ACT_LED1~3	Activity LED of ETH2~4

The 2 LED on top of RJ45 serial port are copy of HDD_LED1 and PSU_LED1

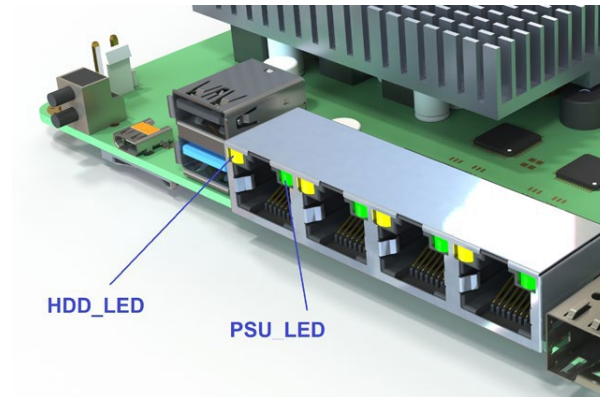

J1

12V power in DC jack, 5.5mm x 2.5mm. It is recommended to use a power supply validated by Boingfire to ensure the reliability of the appliance.

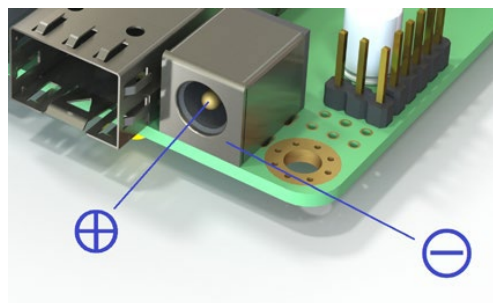

J1 Definition:

PIN	NAME
+	+12VSB (ALWAYS ON)
-	GND

J2

J2 and J1 are wired OR logic, it can be arranged for backup input, depends on client’s demand. The pin header is compatible with Boingfire’s UPS, POE, PSE cards.

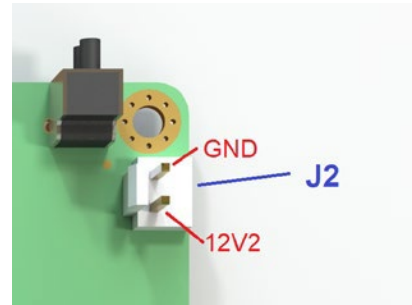
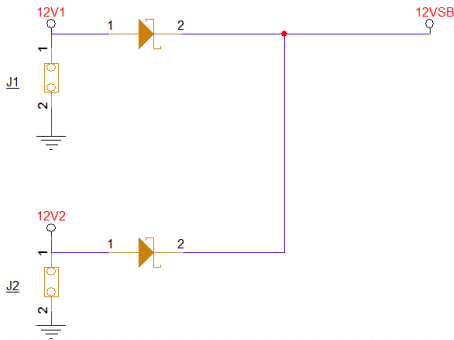

J2 Definition:

PIN	NAME
1	+12VSB (ALWAYS ON)
2	GND

CAUTION:

12V_S (OFF IN S4) and +12VSB (ALWAYS ON) are different power rail.
 Don't wire +12V1 to 12V_S , Short them would damage the motherboard.

USB1 Connector

USB1 connector is accessible externally to connect USB Drive or any USB component.

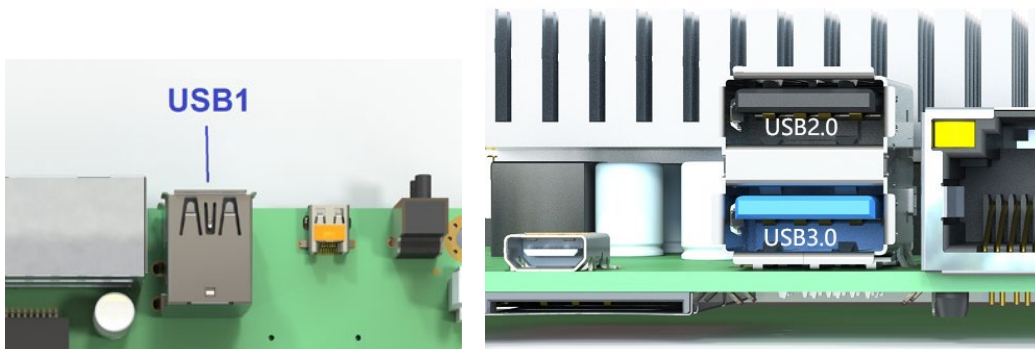

Position	USB Type
Upper Port	USB2.0
Lower Port	USB3.0

USB2 Definition:

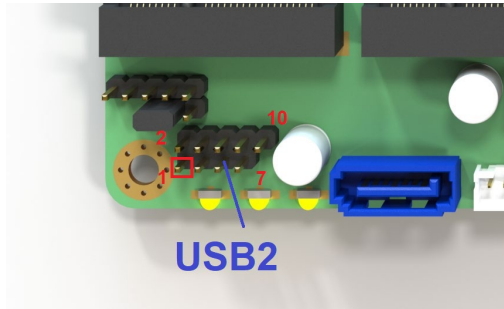

PIN	NAME	PIN	NAME
1	VCC	2	VCC
3	D0-	4	D1-
5	D0+	6	D1+
7	GND	8	GND
		10	GND

mSATA1(SSD)

Support mSATA SSD. SATA 2.0, 3.0 Gb/s

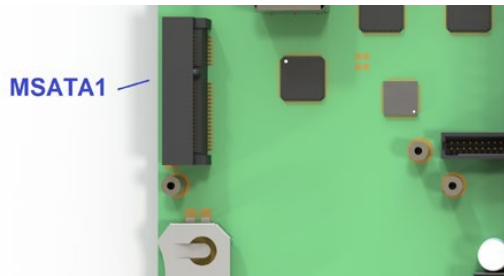

MiniPCIE1 (4G/LTE, Wifi)

Support Wifi, 4G/LTE Module with SIM Holder SIM2 (bottom)

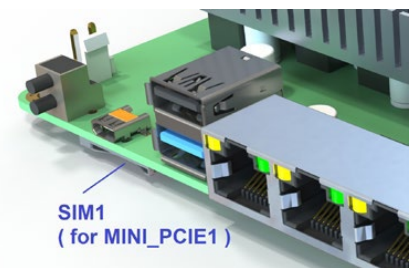
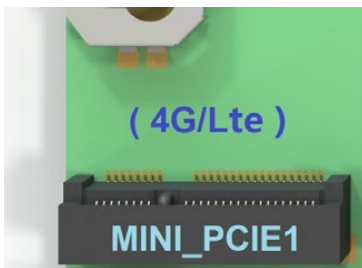

J10

The jumper is used for setting voltage of 4G card in MINI_PCIE1.

In a poor signal environment, if the 4G card can accept maximum voltage of 4V, it is strongly recommended to set this jumper to 3.8V.

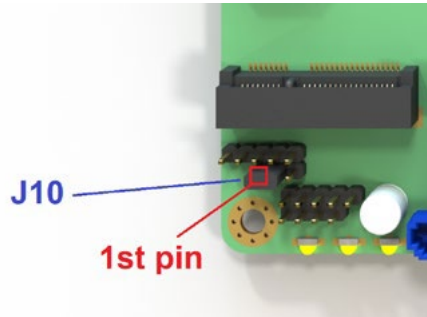

Jumper Setting	Voltage of MINI_PCIE1
1-2 (default)	3.4V
2-3	3.8V

MINI_PCIE2 (4G/LTE, Wifi)

The slot supports the WiFi cards, PCIe Gen2.

Boingfire copper and optical mini PCIe network cards are compatible with the slot.

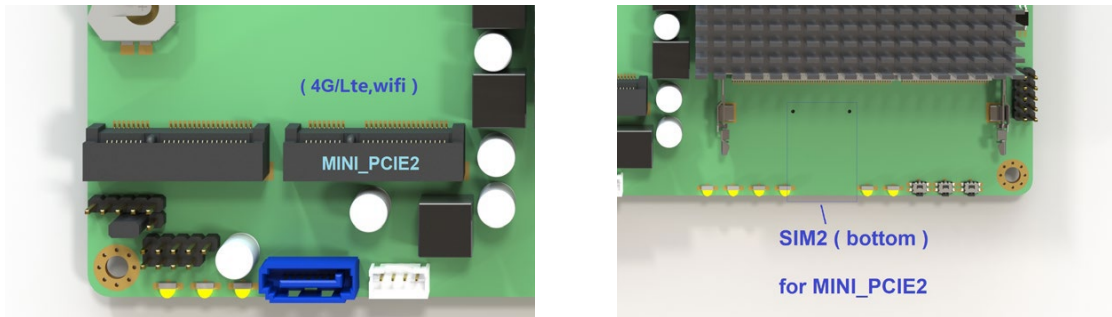

SATA1, PWSATA2

Support SATA 3.5/2.5 inch Hard drive. SAA 2.0, 3.0 Gb/s (300MB/s)

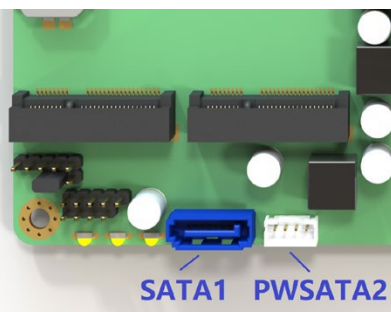

SATA1 Definition

PIN	NAME
1	GND
2	TXP
3	TXN

4	GND
5	RXN
6	RXP
7	GND

PWSATA2 Definition

PIN	NAME
1	VCC
2	GND
3	GND
4	12V_S

RESET1

RESET1 Definition:

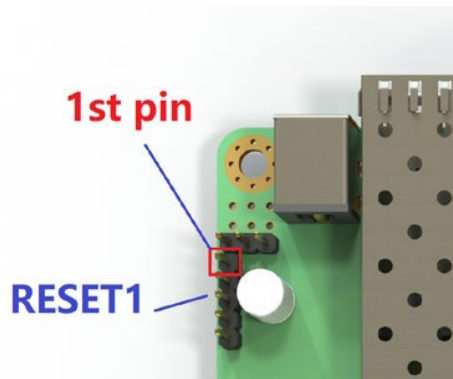

PIN	NAME
1	Power button
2	GND
3	GND
4	RESET#
5	Watchdog_trigger# Active-Low Level

Shorting pin 4~5 means the watchdog will trigger a system reset after WDT timeout. Users can refer to the marks on the bottom of the PCB to wire out the pin headers.

JGPIO1, JGPIO2, JGPIO3

BFN6 has three headers to support up to 20 channels 3.3V GPIO signals. 16 channels are controlled by SOCE3845, and the remaining 4 channels are controlled by SUPERIO IT8772.



JGPIO1 (SOC source)

PIN	NAME	PIN	NAME
1	GP0	2	VCC3
3	GP1	4	GP6
5	GP2	6	GP7
7	GP3	8	GP8
9	GND	10	GP9

JGPIO2 (SOC source)

PIN	NAME	PIN	NAME
1	GP22	2	VCC3
3	GP23	4	GP27
5	GP24	6	GP28
7	GP25	8	GP29
9	GND	10	GP30

JGPIO3 (Super I/O source)

PIN	NAME
1	GP52
3	GP51
5	GP37
7	GP36
9	GND

In order to help developers carry out secondary development on BFN6, Boingfire has tested GPIO development tools, including BF-GPIO-KIT (purchase separately) 3x8 CHGPIO card, and FreeBSD, Linux, windows demo code. Contact sales@boingfire.com for more info.

eMMC1

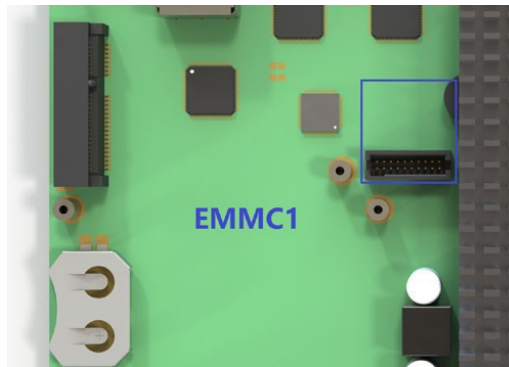

eMMC1 Definition:

PIN	NAME	PIN	NAME
1	eMMC_D0	2	eMMC_D1
3	eMMC_D2	4	eMMC_D3
5	eMMC_D4	6	eMMC_D5
7	eMMC_D6	8	eMMC_D7
9	NC	10	GND
11	eMMC_CMD	12	eMMC_CLK
13	3.3VSB	14	GND
15	1.8VSB	16	1.8VSB
17	eMMC_RESET	18	3.3VSB
19	GND	20	GND

Non-Solder Headers

Some pin headers are not soldered by default. Developers & System integrators can use them flexibly as needed.

Battery holder

Use CS2032 Battery type on BFN6 system board.

PIN	Name
Pin on PCB	Negative (-)
Upper Pin	Positive (+)

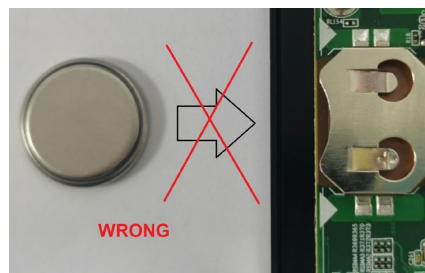
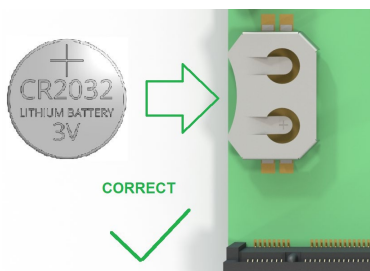
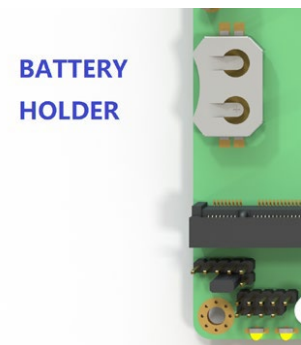

CHAPTER 3: BIOS Settings

BFN6 system board comes with 64bit AMI BIOS. You can access BIOS by pressing DEL button at the time of boot up.

In this section we will cover some basic tasks that will help you to start getting into your system for the configurations and OS installation as per your project requirements.

How to configure BFFTDICON Console Cable?

BFFTDICON cable is made up with the FTDI Chip. There are all the drivers available for all the OS that includes, Linux, MacOS, Windows XP to Windows 11 and Windows CE.

<https://ftdichip.com/drivers/vcp-drivers/>

This link contains all the OS drivers, you can download based on your OS and access through Putty or any other terminal software to access system through Serial Port.

Installation documentation is available on their website as follows:

<https://ftdichip.com/document/installation-guides/>

Windows Issue after driver installation.

After installation of driver you might get the following device in your windows machine and system will not recognize BFFTDICON as COM port.

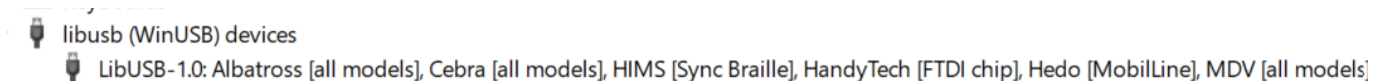

After confirmation that driver is installed, you have to keep cable connected to your Windows machine and follow the instructions below to resolve this issue.

1. Go to your Device Manager
2. Right click on the device showing as LibUSB-1.0.....

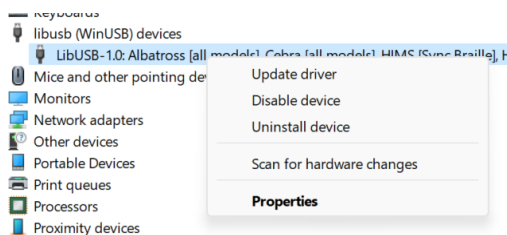

3. Click on update driver

4. You will see this window open, click on Browse my PC for drivers

Browse for drivers on your computer



→ [Let me pick from a list of available drivers on my computer](#)

This list will show available drivers compatible with the device, and all drivers in the same category as the device.

5. Click on **“Let me pick from a list of available drivers on my computer”**
6. You should see this screen if your drivers are already installed.

Select the device driver you want to install for this hardware.

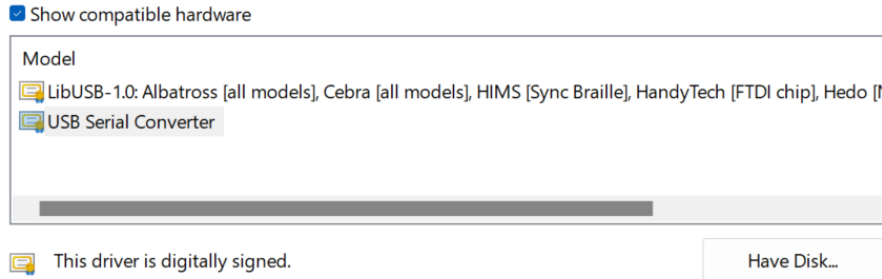
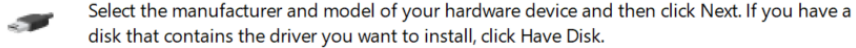

7. Select **“USB Serial Converter”** and proceed.
8. You should see this screen



Windows has successfully updated your drivers

Windows has finished installing the drivers for this device:



9. Now go to your Device Manager and you can see the COM port with the number as showing in the image below.



10. Your computer can show multiple COM ports and the number could be different than this guide.

11. Open PuTTY (Recommended) and select the following configurations.

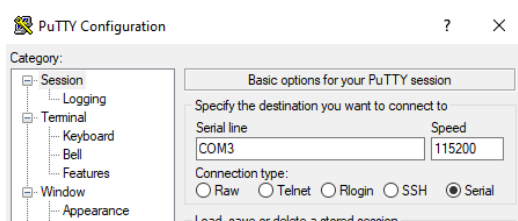
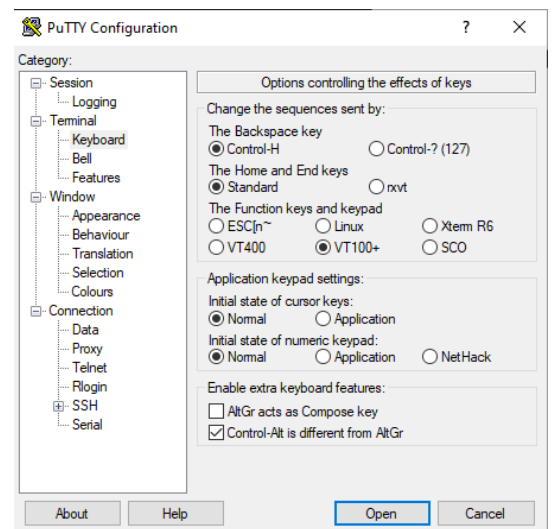
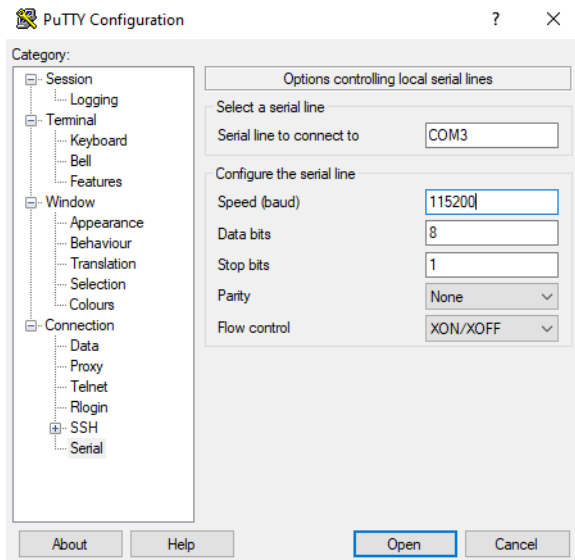

12. Click Open and you should be able to see your Terminal screen now.

Booting BFN6 system from USB.

By default, the system is configured with the UEFI boot option where BFN6 System boots up from the EFI System Partition. To enable the system to boot from USB or other media sources, you must go to BIOS by following the instructions available in this document.

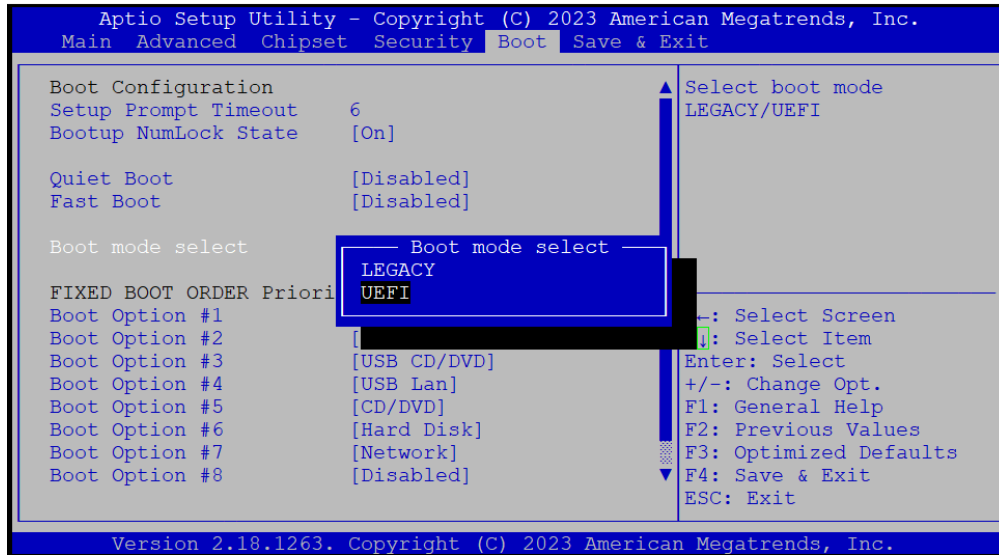

Change Boot Mode from UEFI to LEGACY, Save and Exit. Now your system will boot up from the Sequence of BOOT ORDER

Guidance on Console Redirection Configuration

For optimal system performance and visual output, users are given the capability to manage Console Redirection settings. If the system employs an HDMI port as the primary display output and you are in the process of installing operating systems such as pfSense, OPNSense, or any other OS compatible with Serial Console, an issue may arise during the initial boot from USB.

Specifically, the visual output might cease midway, creating an impression that the system has become unresponsive. This phenomenon is typically due to the COM port redirection capturing part of the display output.

To ensure uninterrupted visual feedback on the monitor connected via HDMI, it's recommended to disable COM port redirection. This adjustment ensures that the entire display output remains consistently visible on the HDMI-connected monitor.

You need to do this activity through BIOS.

Follow these screen shots to Enable/Disable Console Redirection.

1. Restart your system and wait till you get the DEL message to enter into BIOS
2. Go to Advanced Tab and go to

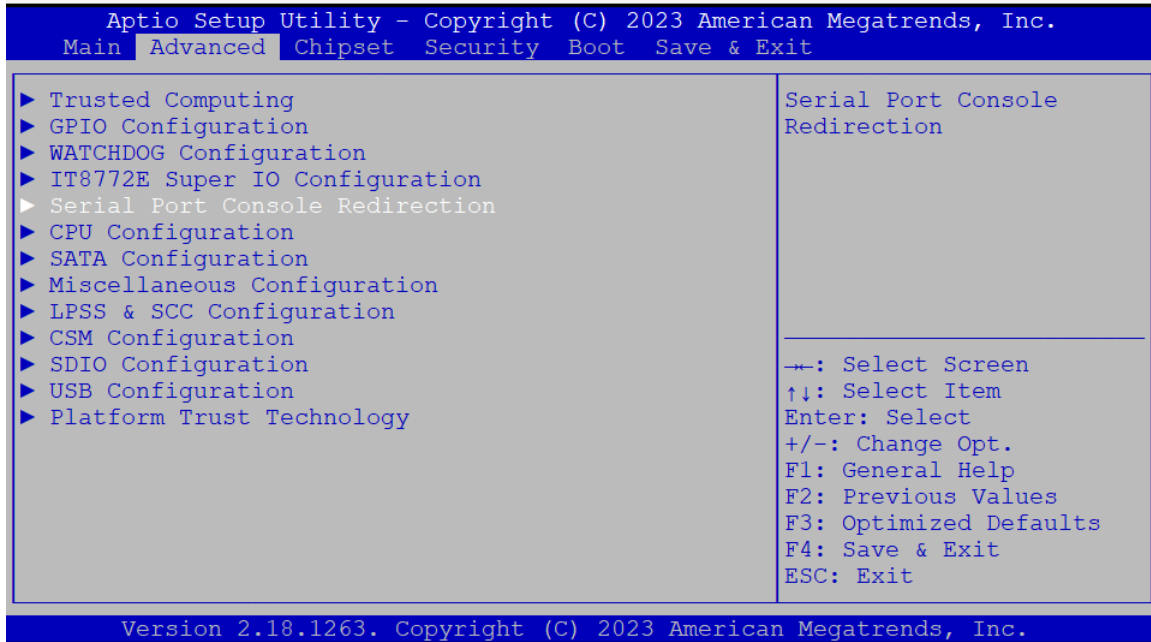

3. Open “Serial Port console Redirection”

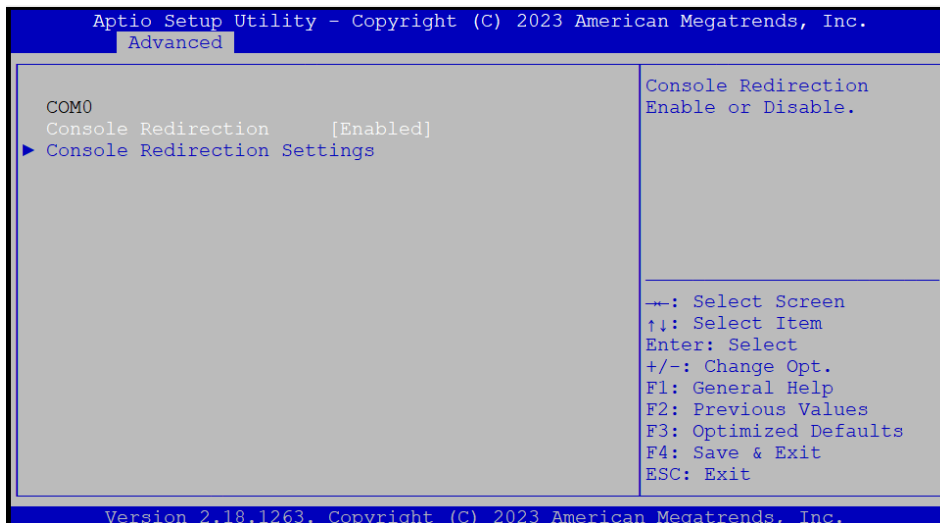

4. You can Enter by selecting the options shown in the step 3 and Disable it if you want to Disable it, or enable it if you want to enable redirection.

You can enable/disable COM Port by following steps.

1. Go to BIOS as mentioned previously and follow the screen shots shown below.

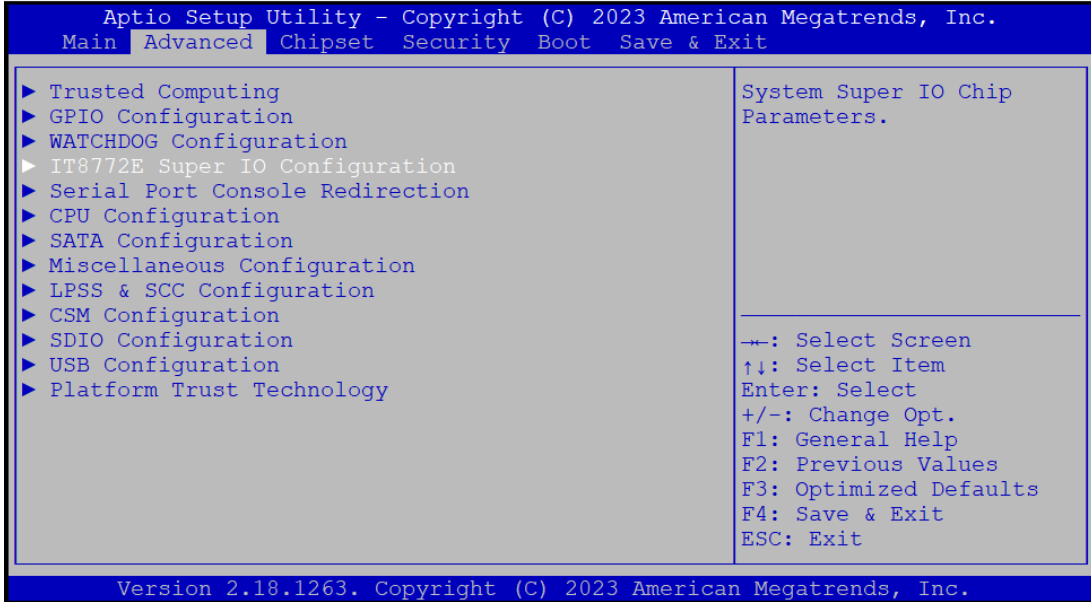

2. Open "IT8772E Super IO Configuration" by pressing Enter
3. Open "Serial Port 1 Configuration"

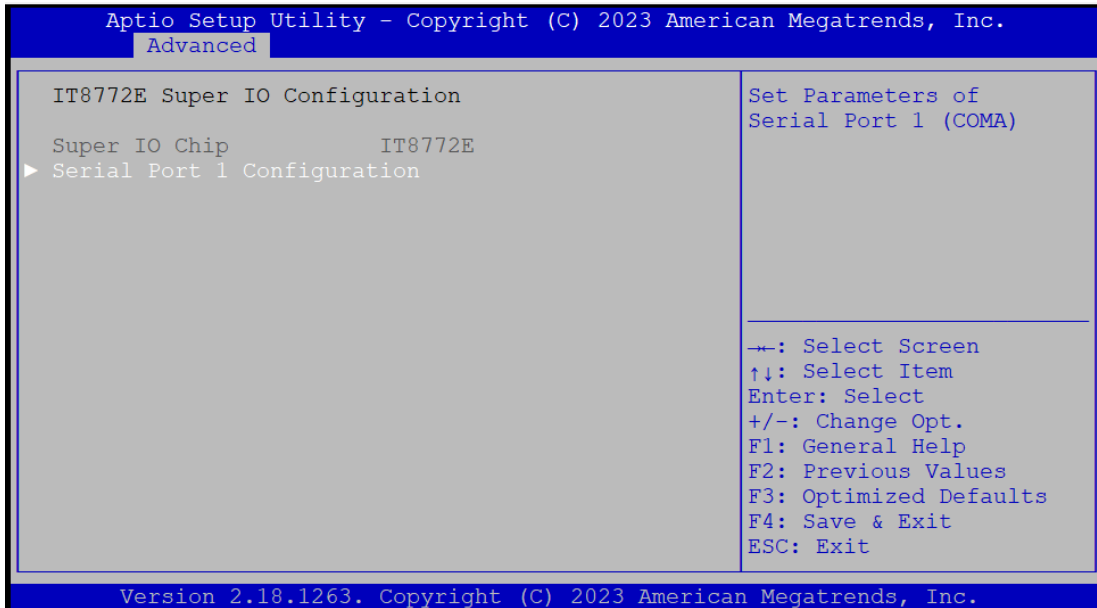

4. Disable by selecting Serial Port and press enter to change settings to Disable or Enable depending on your requirements.

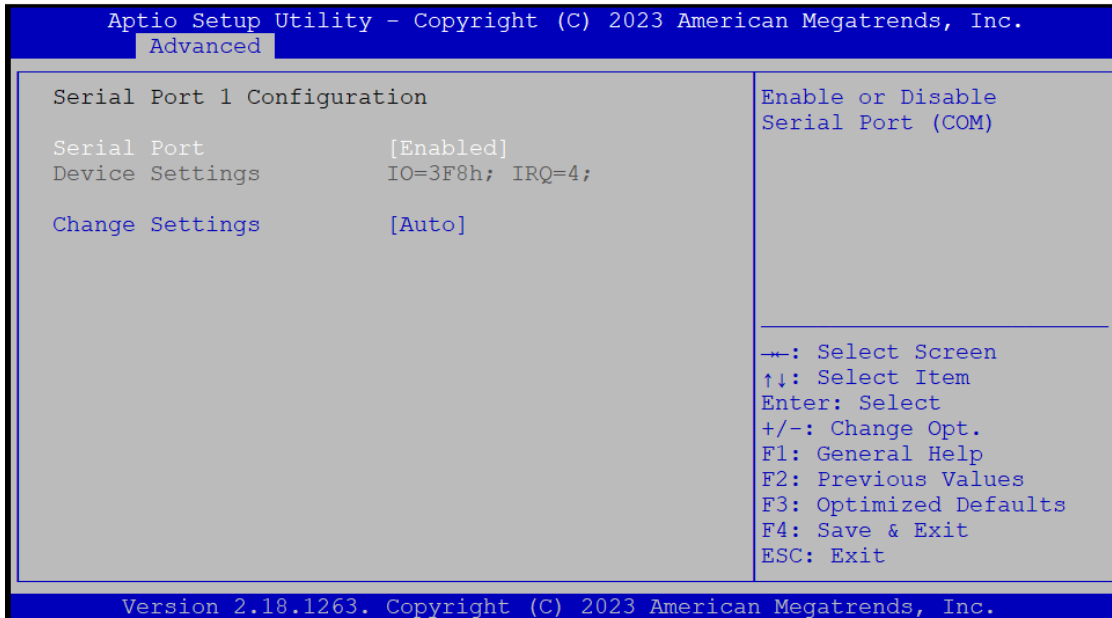

Watchdog settings in the BIOS

1. **System Monitoring:** At its core, the watchdog timer in the AMI BIOS is designed to keep an eye on system operations to ensure that everything is running smoothly.
2. **Automatic Recovery:** It provides an automated recovery mechanism in scenarios where system malfunctions occur. This helps in cases where there might not be immediate human intervention available to reset the system.

BFN6 System board Watchdog Configuration

Go to BIOS and follow the following Screen shots to enable and configure Watchdog.

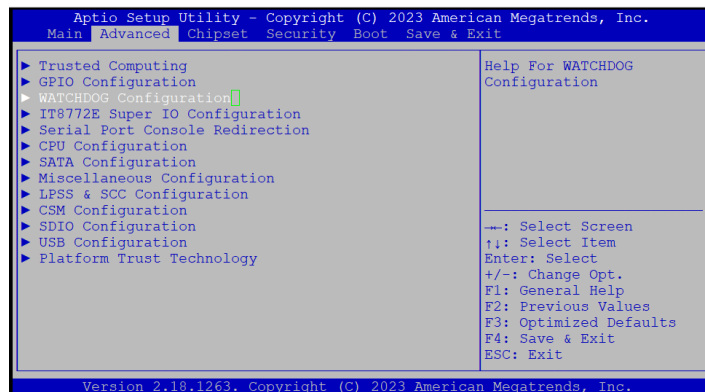

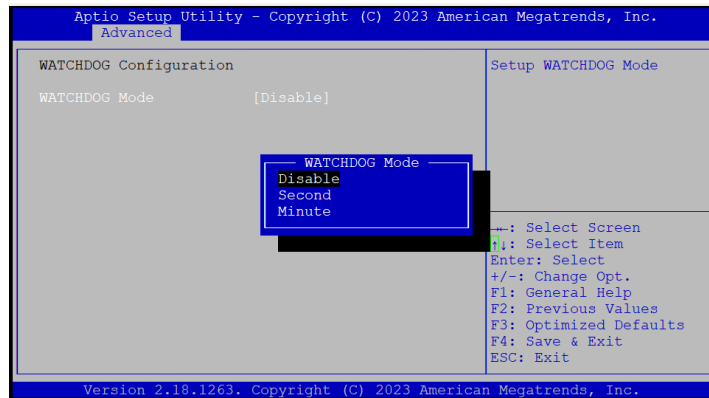
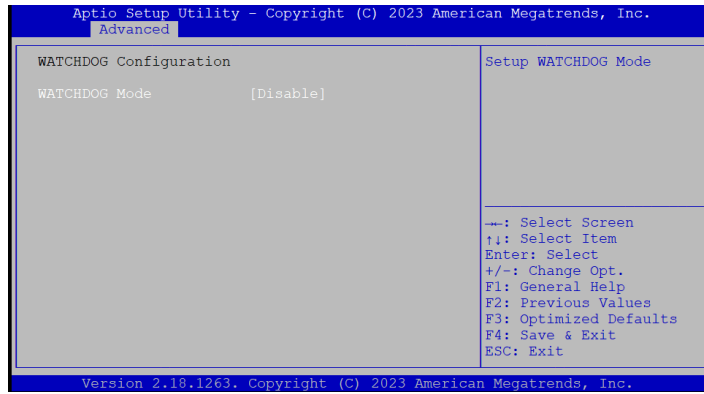

TERMS AND CONDITIONS

Warranty Policy

1. Products come with a one-year warranty from the purchase date, covering defects in materials and craftsmanship.
2. During the warranty period, the buyer covers the shipping costs for returning products for repairs, while the manufacturer pays for the return shipping post-repair.
3. Post-warranty, the buyer is responsible for all repair costs (including parts and labor) and both-way shipping charges.
4. Incomplete or incorrect RMA Service Request Forms will result in the return of items at the customer's expense.
5. Warranty does not cover:
 - Customer's failure to maintain the product properly.
 - Unauthorized alterations, misuse, or backward engineering.
 - Usage beyond the product's specified environmental conditions



7-871 Victoria Street, Unit 173,
Kitchener, ON, N2B 3S4
Canada.

Email: sales@boingfire.com

WEB: <https://boingfire.com>